

# Interspan

Competition Electronic Ignition Systems Specialists

Terence House, 24 London Road

Thatcham, Berkshire RG18 4LQ

Telephone : 01635 866320

M@il : [fred@interspan-ignition.com](mailto:fred@interspan-ignition.com)

Vat Registration No. 209 0857 63



## Installing Instruction Sheet for Interspan Ignition System with Remote Charge

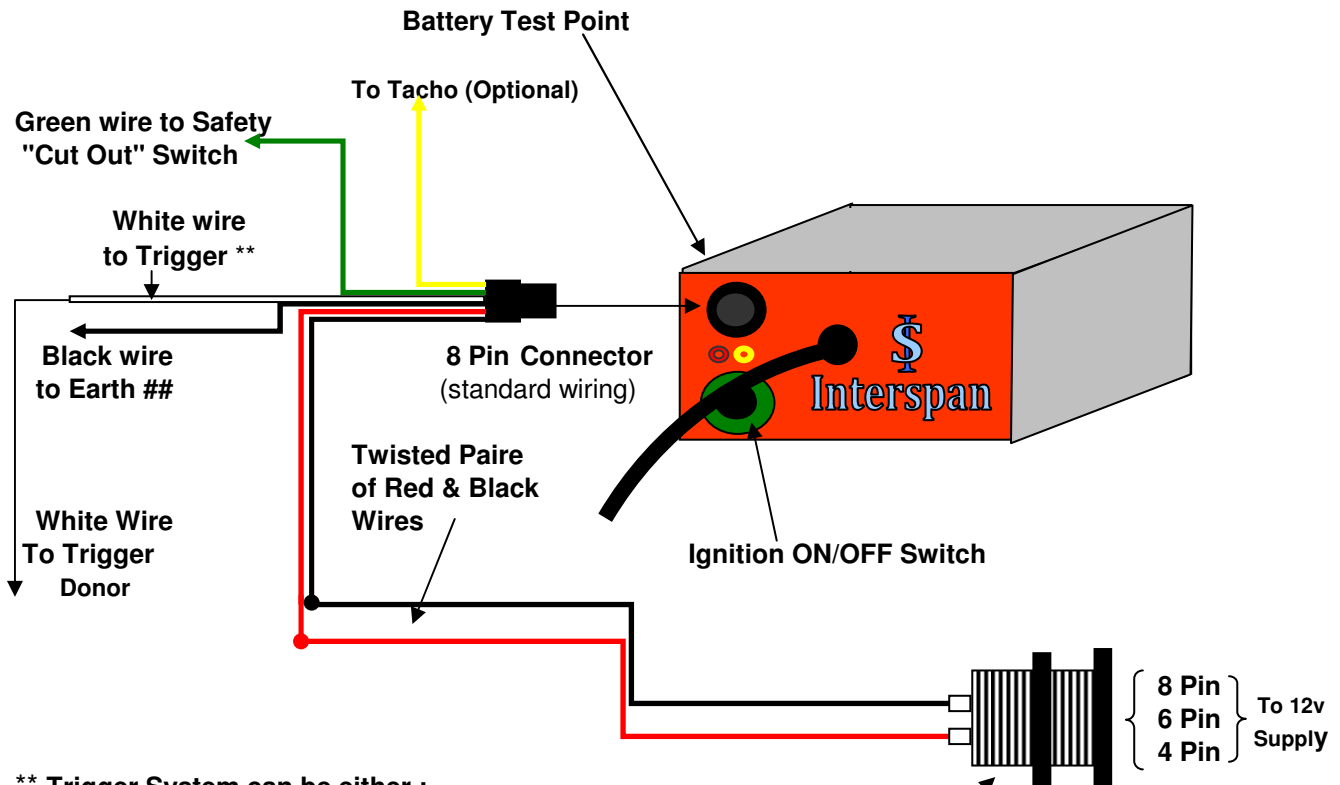

\*\* Trigger System can be either :  
an Interspan "contact-less" or the original points set up (on request).

##

**IMPORTANT :** Make sure that you have a good EARTH connection for the BLACK wire from the Ignition Unit and also the the Black wire on the Trigger set up !  
**BEST TO CONNECT BOTH ON THE ENGINE !**

Remote Charging Socket  
to be fixed on Carenage or Filter Box  
Used to Plug in Charging Lead  
During Race Meetings  
Without dismantling Ignition Box

Please Remember : Switch OFF the Ignition Unit BEFORE connecting the 12v Charging supply !

For any further information Contact or Consult **Interspan**

[www.interspan-ignition.com](http://www.interspan-ignition.com)